

**HYUNDAI**  
CONSTRUCTION EQUIPMENT

# R55w-9A **V** STAGE

HYUNDAI CONSTRUCTION EQUIPMENT EUROPE



MOVING YOU **FURTHER**



# PRIDE AT WORK

Hyundai Heavy Industries strives to build state-of-the-art earthmoving equipment to give every operator maximum performance, optimal controllability, versatile machine settings and proven technology.

***Be proud of your work with Hyundai!***

## R55w-9A

### Machine Walk-Around

#### Engine Technology

The fuel efficient, Yanmar 4TNV98 engine, which meets the strictest European Stage V emission regulations, provides proven, reliable power. This engine is electronically controlled for optimum fuel to air ratio and clean, efficient combustion and provides low noise, anti-restart features.

#### Efficient Control System

All control devices are arranged for higher productivity and improved operator comfort. Efficient and ergonomic controls allow an operator to control the machine in any working environment. A safety lever on the left-side console is provided to prevent exiting the cabin while hydraulic controls are live.

#### Advanced Hydraulic System

The R55W-9A's advanced hydraulic system includes an arm flow summation system, boom holding system and a swing parking brake for smooth and fine control. Other valuable features include a hydraulic damper in the travel pedal, and a hydraulically lubricated swing reducer with a leak-free grease chamber.

#### Comfortable and Durable Cabin

The cabin is roomy and ergonomically designed, for reduced noise and good visibility. The cabin frame meets international standard TOPS, ROPS, FOPS ensuring operator safety.

#### Operator Convenience

Convenient operator features include a suspension seat, excellent visibility, and variable storage space for advanced operator comfort. The newly designed LED cluster provides current information, including engine RPM, engine coolant, fuel level, and electric components. A hydraulic function safety lock and auto diagnostic features are also available. Lock and failure diagnosis functions are also integrated. A powerful air conditioning system and Radio & USB player contribute to a productive work environment.

#### Easy and Simple Maintenance

Wide open access of doors, covers, hoods is designed for easier maintenance. The air cleaner and centralized grease fittings are also integrated for easy service.

#### Extended Life of Components

Long life components and wear parts, including hydraulic filters, oil, shims and bushings, help to reduce operating costs.



\*Photo may include optional equipment.



# PREFERENCE

An operator, who sets his machine to his needs, takes pleasure in his work. Operators can fully customize their work environment and operating preferences to fit their individual needs.

# R55W-9A

## Operator Comfort

In the cabin of our R55W-9A you can experience the highest level of comfort. The ergonomic location of joysticks with arm rests, suspension seat, control levers and LED-display minimizes fatigue of the operator. The LED-display shows all information of the machine with a blink of an eye.

1. A large top glass combined with a roll-up sun visor offers high visibility.
2. An advanced audio system with radio / MP3-player with USB-input, combined with a remote control is installed to listen to your preferred music favorites.
3. Operators are able to call while operating with the hands-free mobile phone feature.
4. Ergonomically designed joysticks reduce operator fatigue.
5. Cabin provides various storage compartments for operator's convenience.



## Stressless

Work is stressful enough; your working environment should be stressless. Hyundai's R55W-9A compact excavator provides many convenient devices for safe and productive work.

1. The window locking device keeps the right window in the preferred position.
2. The sliding front window is easy to open and can be locked safely in open position to improve ventilation and visibility.
3. The tiltable left-side console box offers easy access to the cabin.
4. The powerful temperature control provides the operator with the preferred air temperature.

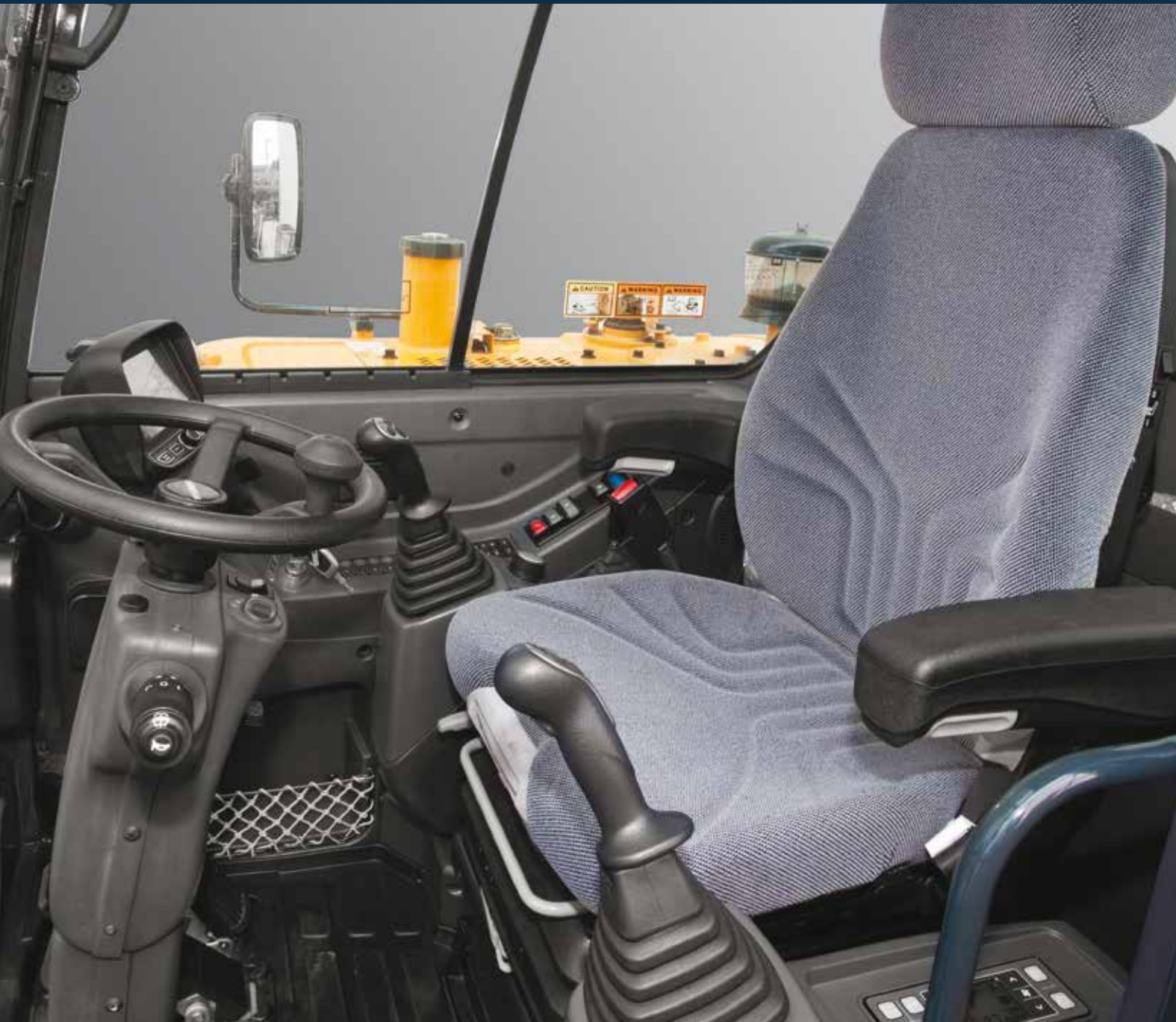
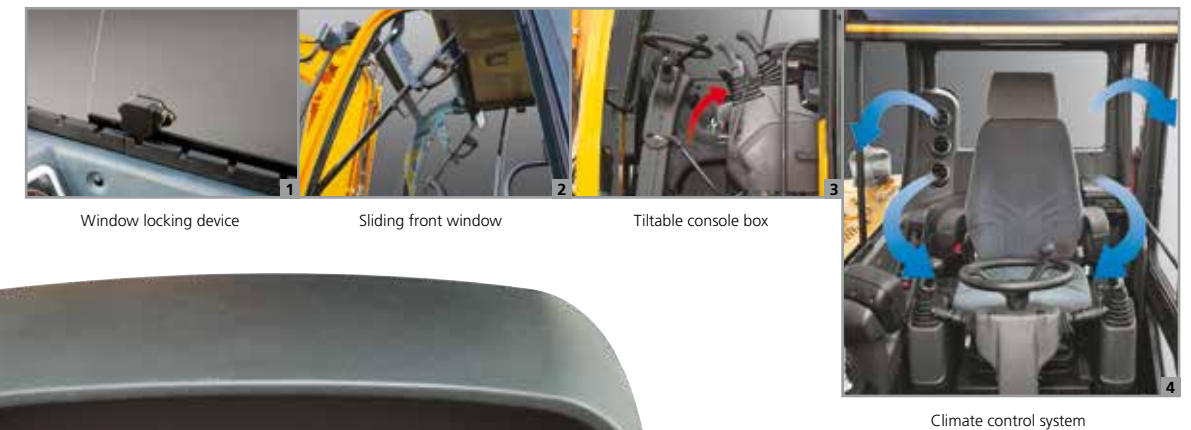

\*Photo may include optional equipment.



### Spacious Cabin with Excellent Visibility

The newly designed cabin was conceived for more space, a wider field of view and operator comfort. Special attention was given to a clear, open and convenient interior with plenty of visibility on the machine surroundings and the job at hand. This well balanced combination of precision aspects put the operator in the perfect position to work safely and securely.



## Easy-to-use Cluster

The advanced LED-cluster allows the operator to select his personal machine preferences. The monitor displays engine rpm, engine temperature and state of electronic devices. The operator can select auto deceleration mode and max power mode and he can control travel speed with the touch of a button. An engine starting lock prevents theft of the machine.



# PERFORMANCE

9A Series deliver fast precision by combining smoother hydraulics with wider view and less stress. Innovative hydraulic system technologies make the R55W-9A excavator fast, smooth and easy to control.



\*Photo may include optional equipment.

## R55W-9A

### Excellent Performance

Hyundai's 9A series offer maximum productivity and high efficiency. With the engine dial, the operator can adjust the engine power to the specific application. A max power button maximizes machine speed and power for maximum productivity. R55W-9A features auto deceleration to reduce fuel consumption and cabin noise level.

### Improved Hydraulic System



To achieve optimum precision, Hyundai redesigned the hydraulic system to provide the operator with super fine touch and high controllability. Improved pump flow control reduces hydraulic flow when controls are not activated to minimize fuel consumption. Improved spool valves in the main control valve are engineered to provide more precise flow to each function with less effort. Improved hydraulic valves, precise variable volume piston pumps, fine-touch pilot controls and enhanced travel functions make any operator of our 9A series look like a smooth operator. Additional features include arm and boom regeneration, combined with automatic boom vs. swing priority for optimal performance in any application.

### Offset Boom

The R55W-9A's boom offset function is designed for efficient work in congested residential and urban areas. The boom can be offset from 80° to the left up to 50° to the right. Increased swing torque provides better operating capability on a slope.

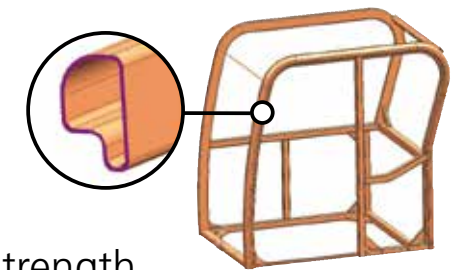

### Structural Strength

The 9A Series cabin structure is designed with slimmer but stronger tubing for more safety and better visibility. Low-stress and high strength steel is welded to form a strong and stable lower frame. Structural durability is analyzed and tested by FEM-analysis (Finite Elements Method) and long-term durability tests.



### Yanmar 4TNV98



The stage V Yanmar engine provides a nominal power of 66.9 HP at 2,400 rpm. This means the R55W-9A runs with the most power in its class, giving you more power to get the job done.



# PROFITABILITY

9A series machines are designed to maximize profitability through improved fuel efficiency, enhanced service features and long-lasting components.



\*Photo may include optional equipment.

# R55W-9A

## Fuel Efficient

9A series compact excavators are engineered to be very fuel efficient.



## Improved Durability

The R55W-9A is equipped with side protection of the counterweight to protect the engine hood. A cover of the dozer cylinder provides extra protection in tough working conditions.



## Easy Maintenance

Centralized grease fittings and easy to change air filter provide faster and easier maintenance.

## Large Engine hood

9A series compact excavator are offering easy access to the engine compartment with a large engine hood.

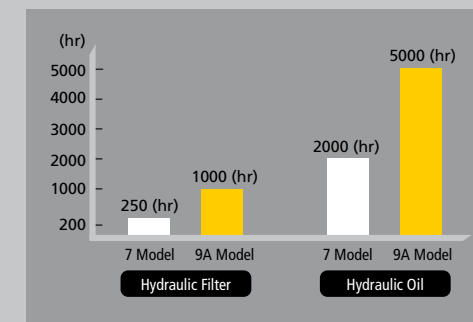

## Extended Life of Components

By adopting long-life hydraulic filters (1000 hrs) and long-life hydraulic oil (5000 hrs) operation costs are reduced. Extended lubricant bush life & ultra high molecular weight polymer shim, more efficient cooling systems and integrated preheating systems are extending service intervals and reducing machine down time.

# SPECIFICATIONS

# R55W-9A

## ENGINE

MODEL	YANMAR 4TNV98		
Type	Water cooled, 4 cycle Diesel, 4-Cylinders in line, direct injection and low emission stage V compliant		
Rated flywheel horse power	SAE	J1995 (gross)	66.9 HP (49.9 kW) / 2,400 rpm
		J1349 (net)	65.1 HP (48.5 kW) / 2,400 rpm
	DIN	6271/1 (gross)	67.8 PS (49.9 kW) / 2,400 rpm
		6271/1 (net)	66 PS (48.5 kW) / 2,400 rpm
Max. torque	24 kgf.m (174 lbf.ft) / 1,560 rpm		
Bore x stroke	98 mm (3.86") x 110 mm (4.33")		
Piston displacement	3,319 cc (203 cu in)		
Batteries	1 x 12 V x 100 Ah		
Starting motor	12 V - 3.0 kW		
Alternator	12 V - 80 A		

## HYDRAULIC SYSTEM

MAIN PUMP	
Type	Two variable displacement axial piston pumps
Max. flow	2 x 62.5 l/min pumps
Sub-pump for pilot circuit	Gear pump
Cross-sensing and fuel saving pump system	
HYDRAULIC MOTORS	
Travel	Two speed axial piston motor with counter balance valve and parking brake
Swing	Axial piston motor with automatic brake
RELIEF VALVE SETTING	
Implement circuits	220 kgf/cm <sup>2</sup> (3,130 psi)
Travel	220 kgf/cm <sup>2</sup> (3,130 psi)
Swing circuit	220 kgf/cm <sup>2</sup> (3,130 psi)
Pilot circuit	30 kgf/cm <sup>2</sup> (430 psi)
Service valve	Installed

## HYDRAULIC CYLINDERS

No. of cylinder-bore x stroke	Boom: 1-110 x 715 mm (4.3" x 28.1")
	Arm: 1-90 x 850 mm (3.5" x 33.5")
	Bucket: 1-80 x 660 mm (3.1" x 26.0")
	Dozer blade: 1-110 x 219 mm (4.3" x 8.6")

## TRAVEL SPEED & GRADEABILITY

Max. travel speed (high) / (low)	30 km/h (18.6 mph) / 11.6 km/h (7.2 mph)
Gradeability	35° (70 %)

## CONTROL

Pilot pressure operated joysticks provide almost effortless and fatigueless operation.

Pilot control	Two joysticks with one safety lever (LH): Swing and arm (RH): Boom and bucket (ISO)
Engine throttle	Electric, Dial type

## SWING SYSTEM

Swing motor	Axial pistons motor
Swing reduction	Planetary gear reduction
Swing bearing lubrication	Grease-bathed
Swing brake	Multi wet disc
Swing speed	7.8 rpm

## COOLANT & LUBRICANT CAPACITY

Refilling	liter	US gal	UK gal
Fuel tank	120.0	31.7	26.4
Engine coolant	9.5	2.5	2.1
Engine oil	11.6	3.1	2.6
Swing device - gear oil	1.5	0.4	0.3
Hydraulic system	120.0	31.7	26.4
Hydraulic tank	70.0	18.5	15.4
Axle (Front / Rear)	5.3 / 5.3	1.4 / 1.4	1.2 / 1.2

## AXLE & TIRES

Full floating front axle is supported by center pin for oscillation. It can be locked by oscillation lock cylinders. Rear axle is fixed on the lower chassis.

Tires	12.0 x 16.5-12PR, single
-------	--------------------------

## DOZER BLADE

Pin-on type dozer blade is standard. Dozer blade is a very useful addition for leveling and back filling or clean-up work.

Dozer blade	Width x height: 1,925 x 355 mm (6' 4" x 1' 2")
	Max. lifting above ground level: 445 mm (17.5")
	Max. depth below ground level: 140 mm (5.5")

## OPERATING WEIGHT (APPROXIMATE)

Operating weight, including 3,000 mm (9' 10") boom, 1,600 mm (5' 3") arm, SAE heaped 0.18 m<sup>3</sup> (0.24 yd<sup>3</sup>) bucket, lubricant, coolant, full fuel tank, full hydraulic tank and all standard equipments.

### MAJOR COMPONENT WEIGHT

Upperstructure	2,680 kg ( 5,910 lb)
Mono boom (with arm cylinder)	310 kg ( 680 lb)

### OPERATING WEIGHT

Operating weight	5,550 kg ( 12,240 lb)
------------------	-----------------------

\* Mono boom with blade

## BUCKETS R55W-9A

Capacity m <sup>3</sup> (yd <sup>3</sup> )		Width mm (in)		Weight kg (lb)
		Without side cutters	With side cutters	
SAE heaped	CECE heaped	315 mm (12.4")	360 mm (14.2")	115 kg (255 lb)
0.07 m <sup>3</sup> (0.09 yd <sup>3</sup> )	0.06 m <sup>3</sup> (0.08 yd <sup>3</sup> )	670 mm (26.4")	740 mm (29.1")	
0.18 m <sup>3</sup> (0.24 yd <sup>3</sup> )	0.15 m <sup>3</sup> (0.20 yd <sup>3</sup> )			170 kg (375 lb)

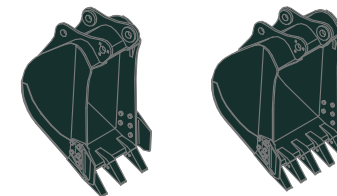

SAE heaped m<sup>3</sup> (yd<sup>3</sup>)

0.07 m<sup>3</sup> (0.09 yd<sup>3</sup>)

0.18 m<sup>3</sup> (0.24 yd<sup>3</sup>)

## DIGGING FORCE R55W-9A

Arm	Length	1,600 mm (5' 3")	1,900 mm (6' 3")
	Weight	210 kg (460 lb)	230 kg (510 lb)
Bucket digging force	SAE	37.7 kN	37.7 kN
		8,490 lbf	8,490 lbf
	ISO	42.4 kN	42.4 kN
		9,550 lbf	9,550 lbf
Arm crowd force	SAE	28.4 kN	25.5 kN
		2,900 kgf	2,600 kgf
	ISO	6,390 lbf	5,730 lbf
		31.9 kN	28.7 kN
		3,260 kgf	2,930 kgf
		7,190 lbf	6,460 lbf

Arm weight includes cylinder and linkage.

## Lifting Capacities

### R55W-9A

Rating over-front Rating over-side or 360 degrees

Boom : 3.0 m (9' 10") / Arm : 1.6 m (5' 3") / Bucket : 0.18 m<sup>3</sup> (0.24 yd<sup>3</sup>) SAE heaped / Dozer blade down

Load point height m (ft)		Load radius								At max. reach				
		2.0 m (7 ft)		3.0 m (10 ft)		4.0 m (13 ft)		5.0 m (16 ft)		Capacity				
5.0 m (16 ft)	kg									*960	*960	4.47		
	lb									*2120	*2120	(14.7)		
4.0 m (13 ft)	kg					*1020	*1020			*990	720	5.26		
	lb					*2250	*2250			*2180	1590	(17.3)		
3.0 m (10 ft)	kg					*1150	1120	*990	760	*1020	620	5.69		
	lb					*2540	2470	*2180	1680	*2250	1370	(18.7)		
2.0 m (7 ft)	kg					*1900	1690	*1400	1070	*1200	740	*1070	570	5.86
	lb					*4190	3730	*3090	2360	*2650	1630	*2360	1260	(19.2)
1.0 m (3 ft)	kg					*2500	1580	*1670	1020	*1310	720	*1110	570	5.81
	lb					*5510	3480	*3680	2250	*2890	1590	*2450	1260	(19.1)
Ground Line	kg	*2690	*2690	*2720	1530	*1820	990	*1350	700	*1160	620	*1160	620	5.51
	lb	*5930	*5930	*6000	3370	*4010	2180	*2980	1540	*2560	1370	*2560	1370	(18.1)
-1.0 m (-3 ft)	kg	*4040	3040	*2610	1520	*1760	980			*1180	740		740	4.92
	lb	*8910	6700	*5750	3350	*3880	2160			*2600	1630		1630	(16.1)
-2.0 m (-7 ft)	kg	*3400	3100	*2090	1550									
	lb	*7500	6830	*4610	3420									

- Lifting capacity is based on SAE J1097, ISO 10567.
- Lifting capacity of the Robex Series does not exceed 75% of the tipping load with the machine on firm, level ground or 87% of full hydraulic capacity.
- The load point is a hook located on the back of the bucket.
- (\*) indicates the load limited by hydraulic capacity.



# R55W-9A

# R55W-9A

## R55W-9A

Rating over-front Rating over-side or 360 degrees

Boom : 3.0 m (9' 10") / Arm : 1.6 m (5' 3") / Bucket : 0.18 m<sup>3</sup> (0.24 yd<sup>3</sup>) SAE heaped / Dozer blade up

Load point height m (ft)		Load radius								At max. reach		
		2.0 m (7 ft)		3.0 m (10 ft)		4.0 m (13 ft)		5.0 m (16 ft)		Capacity		Reach m (ft)
5.0 m (16 ft)	kg lb									*960 *2120	880 1940	4.47 (14.7)
4.0 m (13 ft)	kg lb					*1020 *2250	*1020 *2250			760 1680	650 1430	5.26 (17.3)
3.0 m (10 ft)	kg lb					*1150 *2540	1010 2230	810 1790	690 1520	650 1430	550 1210	5.69 (18.7)
2.0 m (7 ft)	kg lb			1770 3900	1510 3330	1130 2490	960 2120	790 1740	670 1480	610 1340	510 1120	5.86 (19.2)
1.0 m (3 ft)	kg lb			1660 3660	1410 3110	1080 2380	910 2010	760 1680	640 1410	610 1340	510 1120	5.81 (19.1)
Ground Line	kg lb	*2690 *5930	2630 5800	1610 3550	1360 3000	1040 2290	880 1940	750 1650	630 1390	650 1430	550 1210	5.51 (18.1)
-1.0 m (-3 ft)	kg lb	3210 7080	2650 5840	1600 3530	1350 2980	1040 2290	870 1920			790 1740	660 1460	4.92 (16.1)
-2.0 m (-7 ft)	kg lb	3270 7210	2700 5950	1630 3590	1380 3040							

Boom : 3.0 m (9' 10") / Arm : 1.9 m (6' 3") / Bucket : 0.18 m<sup>3</sup> (0.24 yd<sup>3</sup>) SAE heaped / Dozer blade down

Load point height m (ft)		Load radius								At max. reach		
		2.0 m (7 ft)		3.0 m (10 ft)		4.0 m (13 ft)		5.0 m (16 ft)		Capacity		Reach m (ft)
5.0 m (16 ft)	kg lb					*940 *2070	*940 *2070			*880 *1940	840 1850	4.88 (16.0)
4.0 m (13 ft)	kg lb									*910 *2010	650 1430	5.60 (18.4)
3.0 m (10 ft)	kg lb					*1010 *2230	*1010 *2230	*1010 *2230	770 1700	*940 *2070	560 1230	6.00 (19.7)
2.0 m (7 ft)	kg lb	*3000 *6610	*3000 *6610	*1660 *3660	*1660 *3660	*1280 *2820	1080 2380	*1120 *2470	750 1650	*980 *2160	520 1150	6.16 (20.2)
1.0 m (3 ft)	kg lb	*1940 *4280	*1940 *4280	*2330 *5140	1590 3510	*1580 *3480	1020 2250	*1250 *2760	720 1590	*1030 *2270	520 1150	6.10 (20.0)
Ground Line	kg lb	*2520 *5560	*2520 *5560	*2670 *5890	1520 3350	*1770 *3900	980 2160	*1330 *2930	700 1540	*1070 *2360	560 1230	5.83 (19.1)
-1.0 m (-3 ft)	kg lb	*3580 *7890	3000 6610	*2660 *5860	1500 3310	*1790 *3950	970 2140			*1110 *2450	650 1430	5.29 (17.4)
-2.0 m (-7 ft)	kg lb	*3830 *8440	3050 6720	*2290 *5050	1520 3350	*1490 *3280	980 2160			*1080 *2380	910 2010	4.33 (14.2)
-3.0 m (-10 ft)	kg lb	*2070 *4560	*2070 *4560									

Boom : 3.0 m (9' 10") / Arm : 1.9 m (6' 3") / Bucket : 0.18 m<sup>3</sup> (0.24 yd<sup>3</sup>) SAE heaped / Dozer blade up

Load point height m (ft)		Load radius								At max. reach		
		2.0 m (7 ft)		3.0 m (10 ft)		4.0 m (13 ft)		5.0 m (16 ft)		Capacity		Reach m (ft)
5.0 m (16 ft)	kg lb					*940 *2070	*940 *2070			*880 *1940	760 1680	4.88 (16.0)
4.0 m (13 ft)	kg lb									690 1520	580 1280	5.60 (18.4)
3.0 m (10 ft)	kg lb					*1010 *2230	*1010 *2230	810 1790	690 1520	600 1320	500 1100	6.00 (19.7)
2.0 m (7 ft)	kg lb	*3000 *6610	2990 6590	*1660 *3660	1540 3400	1140 2510	970 2140	790 1740	670 1480	560 1230	470 1040	6.16 (20.2)
1.0 m (3 ft)	kg lb	*1940 *4280	*1940 *4280	1670 3680	1420 3130	1080 2380	920 2030	760 1680	640 1410	560 1230	460 1010	6.10 (20.0)
Ground Line	kg lb	*2520 *5560	*2520 *5560	1600 3530	1350 2980	1040 2290	880 1940	740 1630	620 1370	590 1300	500 1100	5.83 (19.1)
-1.0 m (-3 ft)	kg lb	3160 6970	2610 5750	1580 3480	1330 2930	1020 2250	860 1900			690 1520	580 1280	5.29 (17.4)
-2.0 m (-7 ft)	kg lb	3210 7080	2650 5840	1600 3530	1350 2980	1040 2290	870 1920			960 2120	810 1790	4.33 (14.2)
-3.0 m (-10 ft)	kg lb	*2070 *4560	*2070 *4560									

- Lifting capacity is based on SAE J1097, ISO 10567.
- Lifting capacity of the Robex Series does not exceed 75% of the tipping load with the machine on firm, level ground or 87% of full hydraulic capacity.
- The load point is a hook located on the back of the bucket.
- (\*) indicates the load limited by hydraulic capacity.

## DIMENSIONS R55W-9A

mm (ft · in)

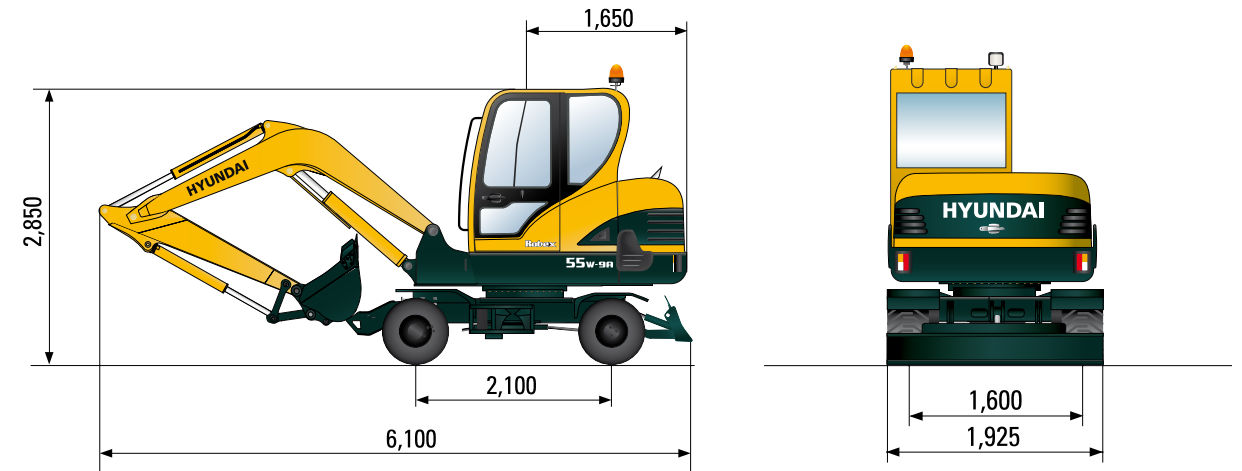

## WORKING RANGE R55W-9A

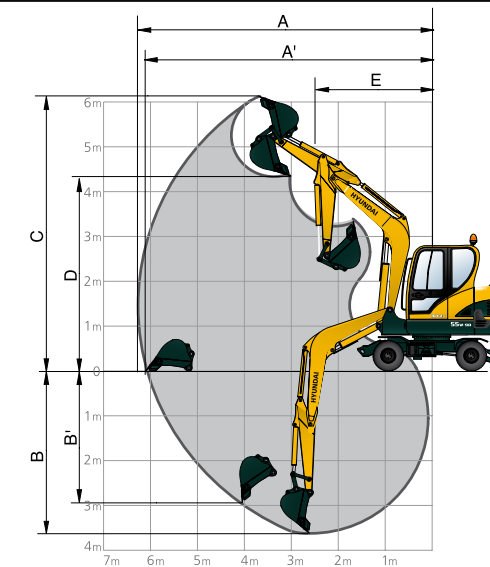

mm (ft · in)

Boom length	3,000 (9' 10")	
Arm length	1,600 (5' 3")	1,900 (6' 3")
A Max. digging reach	6,150 (20' 2")	6,430 (21' 1")
A' Max. digging reach on ground	5,980 (19' 7")	6,200 (20' 4")
B Max. digging depth	3,500 (11' 6")	3,800 (12' 6")
B' Max. vertical wall digging depth	2,960 (9' 9")	3,160 (10' 4")
C Max. digging height	6,070 (19' 11")	6,260 (20' 6")
D Max. dumping height	4,340 (14' 3")	4,530 (14' 10")
E Min. front swing radius	2,350 (7' 9")	2,350 (7' 9")
F Tail swing radius	1,650 (5' 5")	1,650 (5' 5")



# R55w-9A

## STANDARD EQUIPMENT R55W-9A

ISO standard cabin
Cabin ROPS (ISO 3471)
FOPS (ISO 3449)
FOG (ISO 10262 Level I)
TOPS (ISO 12117)
All-weather steel cab with all-around visibility
Safety glass windows
Rise-up type windshield wiper
Sliding fold-in front window
Sliding side window
Lockable door
Storage compartment & Ashtray
Centralized monitoring
Engine speed
Gauges
- Fuel level gauge
- Engine coolant temperature gauge
Warning lamps
- Fuel level
- Engine oil pressure
- Engine coolant temperature
- Hyd. oil temperature
- Low battery
- Air cleaner clogging
Door and locks, one key fits all
Radio / USB Player
Two outside rearview mirrors
Mechanical suspension seat with heater
Console box tilting system (LH.)
Front working lights
Electric horn
Battery (1 x 12 V x 100 Ah)
Battery master switch
12 volt power supply
Removable clean-out screen for coolers
Automatic swing brake
Water separator, fuel line
Mono boom (3.0 m; 9' 10")
Arm (1.6 m; 5' 3")
Tires (12.0 x 16.5 - 12PR, single)
Dozer blade (1925 x 354 mm; 6'4" x 14")
Starting Aid (air grid heater) for cold weather
Safety lock valve for boom cylinder with overload warning device
Safety lock valve for arm cylinder
Safety lock valve for dozer blade cylinder
Air conditioner & heater
Fuel filler pump (35 ℓ/min)
Double acting piping (clamshell, etc)
Accumulator, work equipment lowering

## OPTIONAL EQUIPMENT R55W-9A

Beacon lamp
Single acting piping (Breaker, etc)
Quick coupler
Long arm (1.9 m; 6'3")
Narrow bucket (0.07 m <sup>3</sup> ; 0.09 yd <sup>3</sup> )
Tool kit
Front working lights cabin

- \* Standard and optional equipment may vary. Contact your Hyundai dealer for more information. The machine may vary according to International standards.
- \* The photos may include attachments and optional equipment that are not available in your area.
- \* Materials and specifications are subject to change without advance notice.
- \* All imperial measurements rounded off to the nearest pound or inch.
- \* The air conditioning system on this machine contains the fluorinated greenhouse gas refrigerant HFC-134a (Global Warming Potential = 1430). The system contains 0.95 kg of refrigerant which has a CO<sub>2</sub> equivalent of 1.3585 metric tonne.







Specifications and design are subject to change without notice. Pictures of Hyundai Construction Equipment Europe products may show other than standard equipment.

Hyundai Construction Equipment Europe nv,  
Hyundailaan 4, 3980 Tessenderlo, Belgium.  
Tel: (32) 14-56-2200 Fax: (32) 14-59-3405

EN - 2021.03 REV/3

**Ready to experience the Hyundai Effect?  
Contact your Hyundai dealer.  
[hyundai-ce.eu/en/dealer-locator](https://hyundai-ce.eu/en/dealer-locator)**

